

Hope in the Car Industry (by Popular Demand)

May 21, 2008

**Felix Kramer, Founder
The California Cars Initiative
fkramer@calcars.org**

***PDF of latest presentation at
www.calcars.org/downloads***



Popular Science



CalCars

THE CALIFORNIA CARS INITIATIVE

www.calcars.org

Electricity isn't just different—it's better than gas

Gasoline	Self Serve
Today's Car	3.00 ¹ / ₁₀ ⁹ / ₁₀
Plug-In Hybrid	.75 ¹ / ₁₀ ⁹ / ₁₀

1. **ECONOMICS: CHEAPER** --
electric miles at a quarter the cost



2. **CLIMATE: CLEANER** --
50% less CO₂, even on our
half-coal national power grid

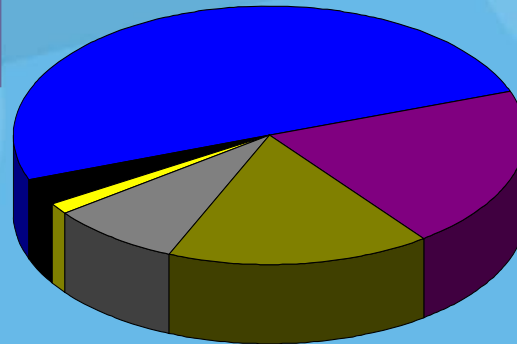

3. **ENERGY SECURITY: DOMESTIC** --
Only 1.5% of
electricity comes
from oil in US



CalCars

THE CALIFORNIA CARS INITIATIVE

www.calcars.org

Today's hybrid evolves into the plug-in hybrid

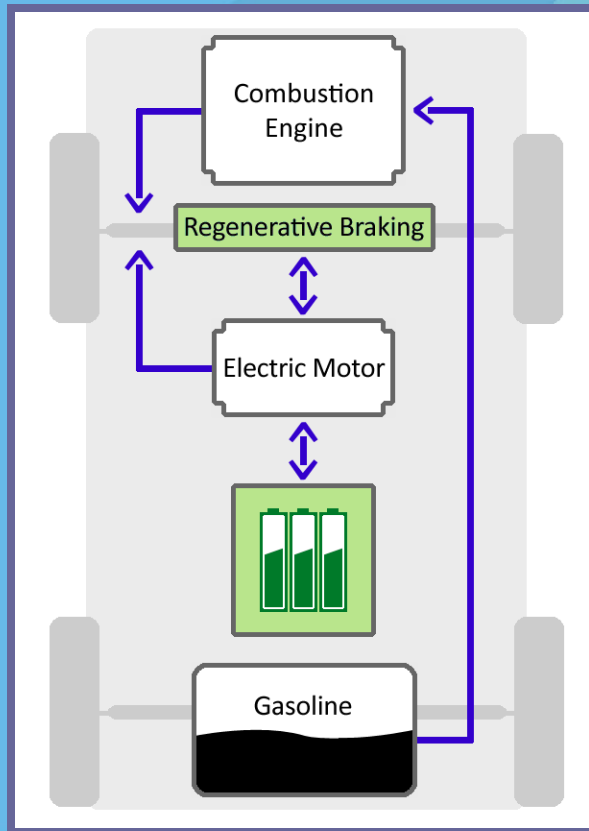

HYBRID to PLUG-IN HYBRID

SMALLER gasoline engine
(same regeneration)

SAME/LARGER electric motor

MUCH LARGER battery

NEW: Plug into the grid

(same gas tank)

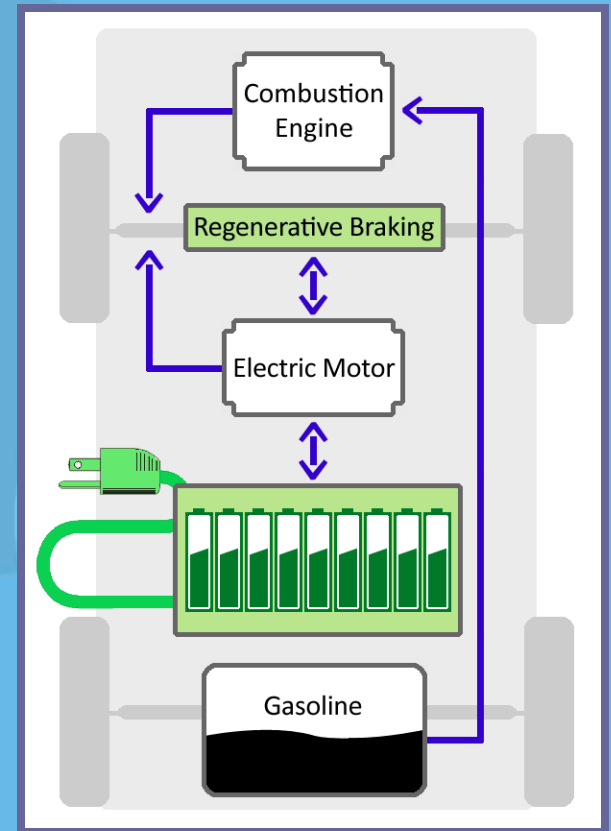

CalCars

THE CALIFORNIA CARS INITIATIVE

Modified from an EDTA diagram concept

www.calcars.org

Hope in the Car Industry

My car gets 100+ MPG (plus 1cent/mile for electricity)



CalCars

THE CALIFORNIA CARS INITIATIVE

www.calcars.org

Unprecedented campaign unites constituencies

**“A coalition between the tree-huggers, the do-gooders, the sod-busters, the cheap hawks, and the evangelicals.”
– former CIA Director James Woolsey**



CalCars

THE CALIFORNIA CARS INITIATIVE

www.calcars.org

Hope in the Car Industry

12+ carmakers interested; race to be first; still no timetables (*CalCars "Carmakers" page tracks statements*)



Daimler Sprinter PHEV;
Chrysler: new electric division



TOYOTA

**By 2010,
400-vehicle
demo fleet**



"Within 5-10 years" –

Volvo may be sooner



BYD AUTO
Build Your Dreams



Saturn Vue possible 2010; Chevy Volt: 2010 mass production (goal); then Opel Flextreme



**Fleet 2010,
production
2012**

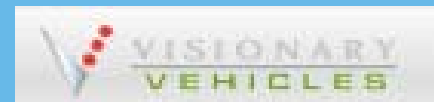

**Interest/plans: Loremo,
Gordon Murray**



CalCars

THE CALIFORNIA CARS INITIATIVE

www.calcars.org

What's taking so long? The wait for Version 1.0



Without “The Brick” for \$3,995,
would we have the Razr & iPhone?
\$1,000 plasma TVs started at \$10,000.



Toyota: maybe 2011 –
why not in 2008-2009?



Chevy Volt : goal is late 2010 --
we urge 2009 demo fleets.

A dozen other automakers:
PHEVs a good idea – someday.



CalCars

THE CALIFORNIA CARS INITIATIVE

www.calcars.org

All Three Potential Presidents Endorse PHEVs



Capitol Hill May '06



Wayne, MI Ford plant
Feb '08



Googleplex Nov '07



CalCars

THE CALIFORNIA CARS INITIATIVE

www.calcars.org

Hope (by Popular Demand)

Felix Kramer, Founder
The California Cars Initiative
fkramer@calcars.org



CalCars

THE CALIFORNIA CARS INITIATIVE

www.calcars.org