

Hope in the Car Industry (by Popular Demand)

TED 08 Feb 29, 2008

**Felix Kramer, Founder
The California Cars Initiative
fkramer@calcars.org**



Popular Science



CalCars

THE CALIFORNIA CARS INITIATIVE

www.calcars.org

Electricity isn't just different—it's better than gas

Gasoline	Self Serve
Today's Car	3.00 ¹⁹ / ₁₀
Plug-In Hybrid	.75 ⁹ / ₁₀

1. CHEAPER:
electric miles at a quarter the cost



2. CLEANER:
50% less CO₂ – even on our half-coal national power grid

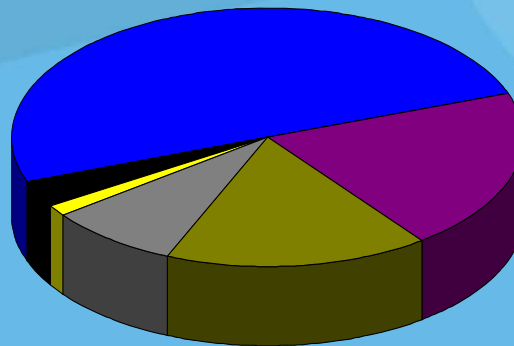

3. DOMESTIC:
Only 1.5% of electricity comes from oil in US



CalCars

THE CALIFORNIA CARS INITIATIVE

www.calcars.org

Today's hybrid evolves into the plug-in hybrid

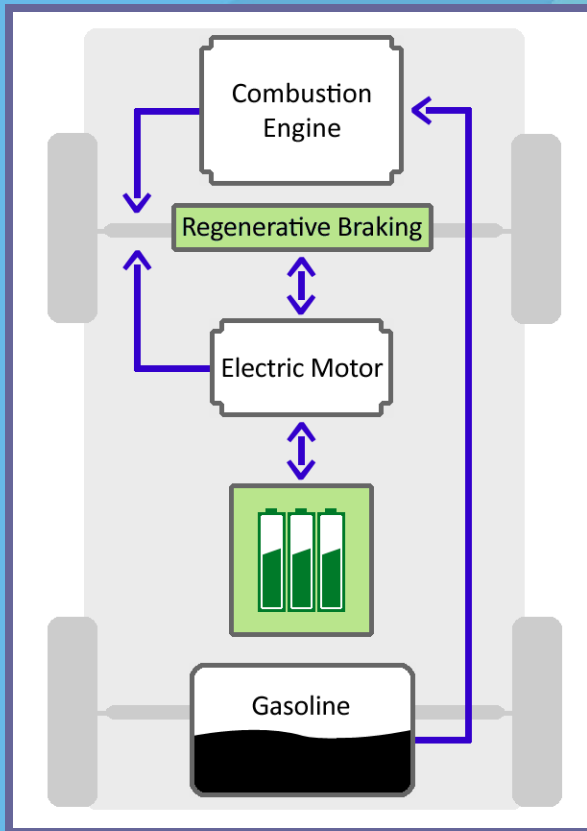

HYBRID to PLUG-IN HYBRID

SMALLER gasoline engine
(same regeneration)

SAME/LARGER electric motor

MUCH LARGER battery

NEW: Plug into the grid

(same gas tank)

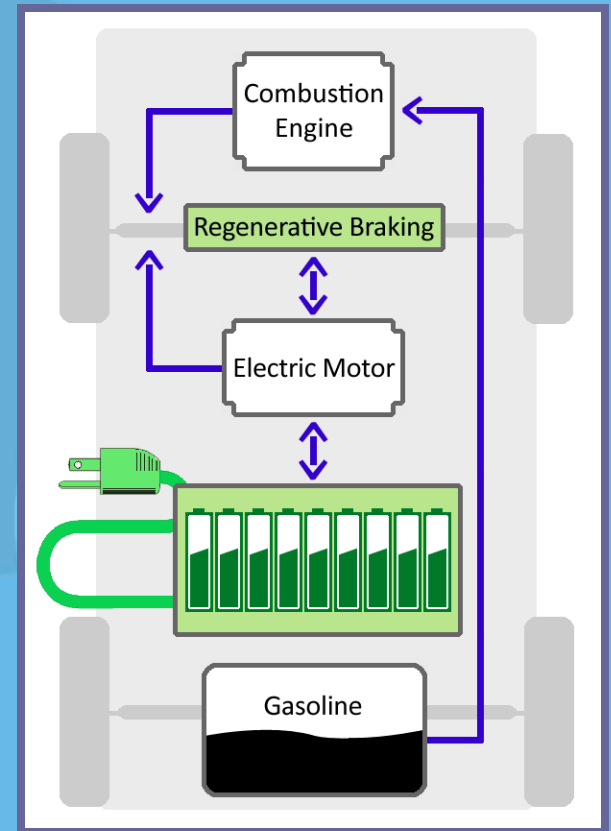

CalCars

THE CALIFORNIA CARS INITIATIVE

www.calcars.org

Hope in the Car Industry

My car gets 100+ MPG (plus 1cent/mile for electricity)



CalCars

THE CALIFORNIA CARS INITIATIVE

www.calcars.org

Unprecedented campaign; carmakers say OK, but...

**“A coalition between the tree-huggers,
the do-gooders, the sod-busters, the
cheap hawks, and the evangelicals.”
– former CIA Director James Woolsey**



CalCars

THE CALIFORNIA CARS INITIATIVE

www.calcars.org

What's taking so long? The wait for Version 1.0



Without “The Brick” for \$3,995,
would we have the Razr & iPhone?
\$1,500 plasma TVs started at \$10,000.



Toyota: maybe 2011 –
why not in 2008-2009?



Chevy Volt : goal is late 2010 --
we urge 2009 demo fleets.

A dozen other automakers:
PHEVs a good idea – someday.



CalCars

THE CALIFORNIA CARS INITIATIVE

www.calcars.org

Hope (by Popular Demand)

Felix Kramer, Founder
The California Cars Initiative
fkramer@calcars.org



CalCars

THE CALIFORNIA CARS INITIATIVE

www.calcars.org